

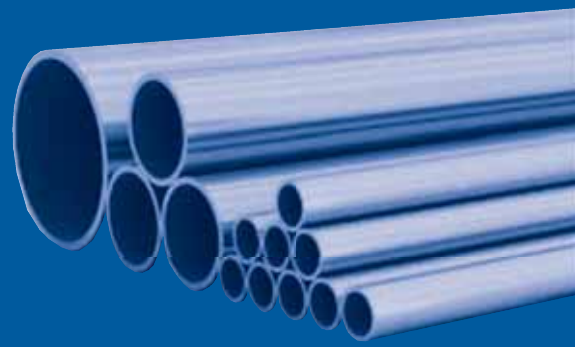

Pennar Industries Limited
Engineering Excellence

ENGINEERED TUBULAR SOLUTIONS

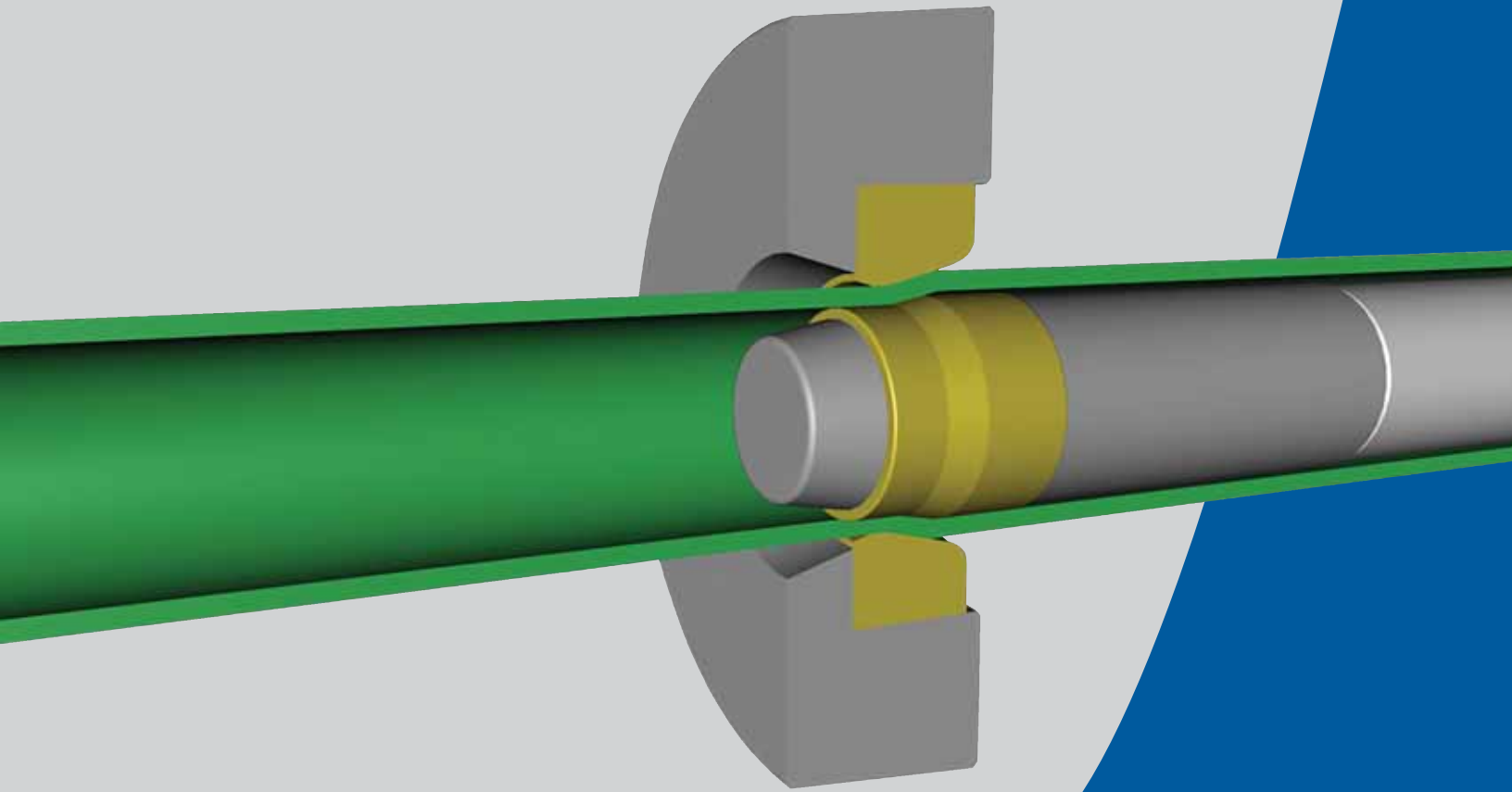

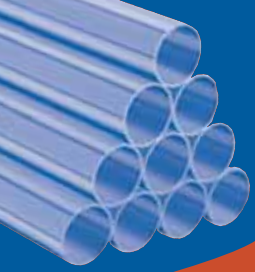

Pennar Industries

Engineering India

Our Vision

Our vision is to be a globally reputed engineered metal products company. We endeavour to have a strong and enduring relationship with our customers based on quality and service.

Pennar Industries Limited (PIL) is one of the leading engineering organizations in India renowned for providing innovative engineering solutions. An epitome of quality, precision and perfection, Pennar is a professionally managed company of more than 1500 strong team members. Pennar is driven by an unrelenting desire to excel with experience and expertise spanning over three decades. Pennar is a multi-location, multi-product company manufacturing cold rolled steel strips, precision tubes, cold rolled formed sections, ESP electrodes, profiles, railway wagon and coach components, solar structures, storage solutions, pressed steel components and road safety systems.

Pennar Group, of which PIL is a part, has more than 1500 employees with an annual turnover of more than Rs.1200 crores. The Group has three main entities, namely, Pennar Industries Limited, PEBS Pennar and Pennar Enviro Limited. Pennar Industries Limited is the parent company of the Pennar Group. PEBS Pennar and Pennar Enviro Limited are its subsidiaries.

PIL, established in the year 1988, has grown since then by leaps and bounds widening its spectrum of engineering products. Pennar covers a whole range of products catering to various segments such as infrastructure, automobiles, energy, general engineering and others. The company has stratified its business into strategic business units, namely, Steel Products, Industrial Components, Systems and Projects, Tubes.

PIL has a pan-India presence with five manufacturing facilities situated across the country. These facilities include laser cutting, plasma cutting, transfer presses and CNC machines that enable it to make products of very high quality.

Driven by our guiding philosophy of maximizing customer satisfaction with products and services par excellence, today we have successfully established our identity as a Powerhouse of Engineering Excellence.



Railway Products



Automobile Products



Pressed Components



Roof Sheetting



Heavy Engineering Fabrications



Road Safety Systems



ESP Electrodes



Sheet Piles



Cold Rolled Coils

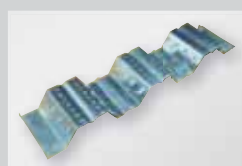

Deck Plates



Railway Wagon

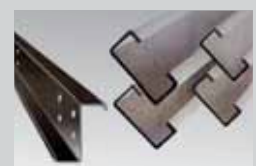

C & Z Purlins

CDW Process Flow

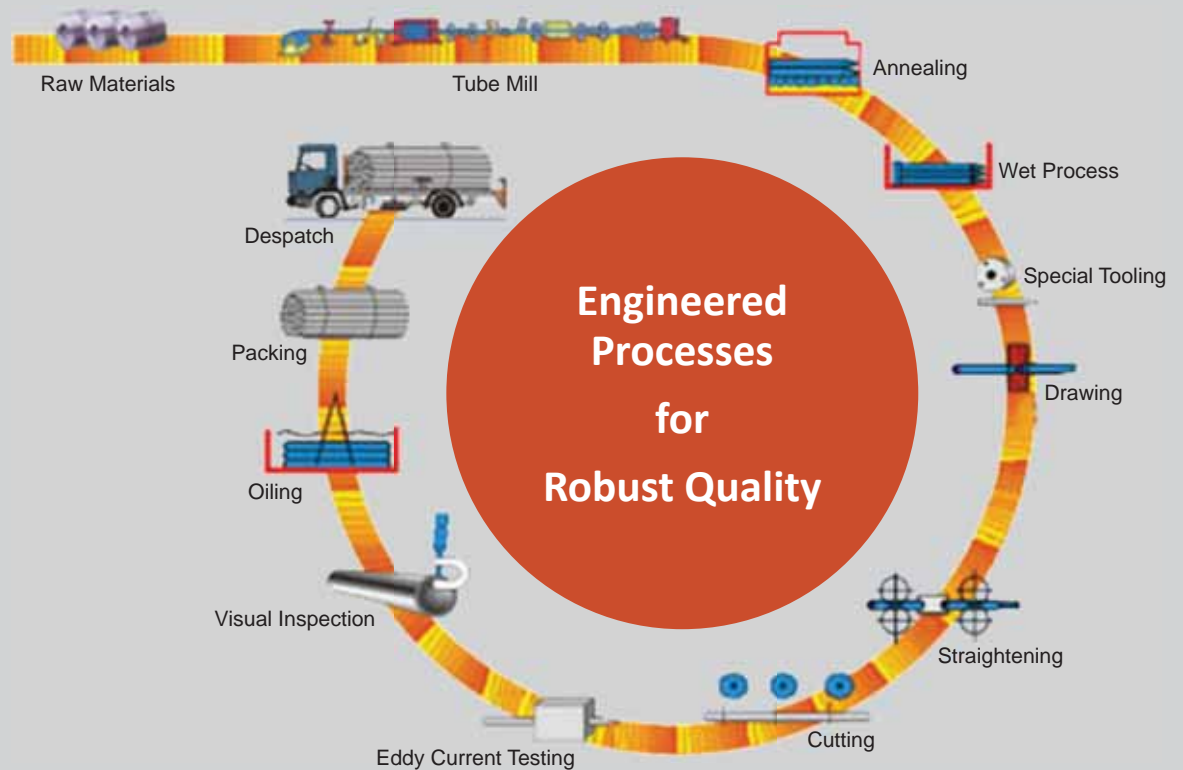

Manufacturing Process

Raw Material Preparation

The raw material required for tube making is a steel strip which undergoes various stages of processing. HR or CR strips in the form of coil is procured from indigenous steel makers or from import sources and are used in the manufacture of a tube depending on the application.

Manufacturing begins in a separate preparatory section where the strip is slit into required width depending on the diameter of the tube & subjected to acid pickling process to remove all rust and scale in an ultra modern strip pickling plants.

Separate in-house cold rolling mills also cater to raw material requirements for closer dimensional tolerances and bright surface finish of tubes.

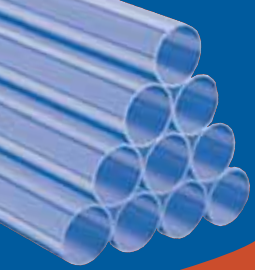

ERW Tube Making

...Manufacturing Process



Electric Resistance Welded (ERW) tubes are made by forming the steel strip into a tubular round section by progressive movement through a set of specially designed rolls. The butted ends of the strip are welded by high frequency induction welding process without any filler material. The hot weld-flash formed due to welding is removed internally (fin-cut) and externally by the deburring units. Turks head and sizing rolls provided at the end of the tube mill ensure straightening and sizing of the tubes into required sections like rectangular, square, elliptical and oval. The tubes are cut into required length and undergo annealing, pressure testing, eddy current testing, straightening or cutting depending upon the applications.

ERW Product Range

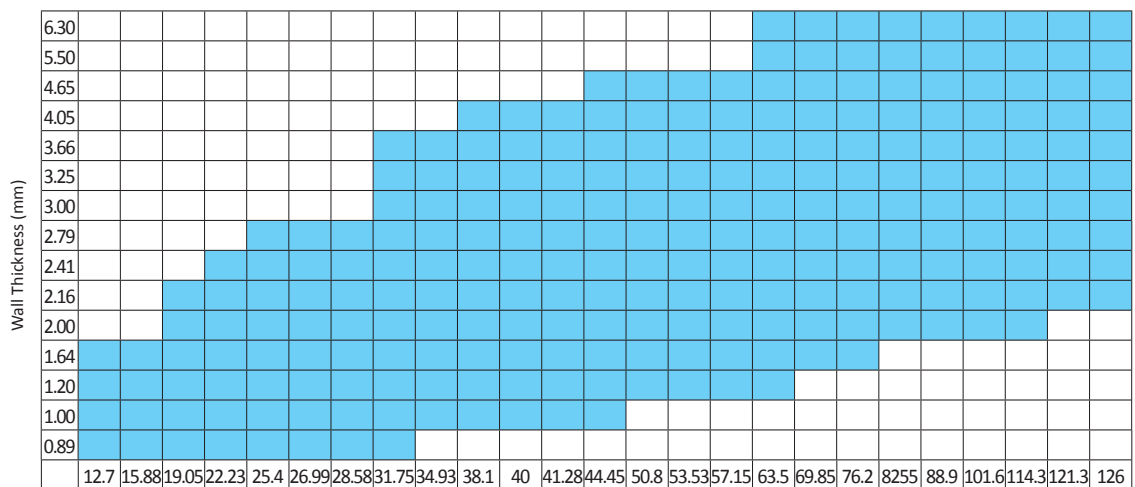

Outside Diameter (mm)

Automobiles

- Front fork Top / Bottom
- Steering column
- Two wheeler main frame
- Bottom chassis
- Fuel tank spacer
- Swing arm
- Propeller shaft
- Seat frame
- Tie rod
- Rocker arm shaft
- Catalytic converter
- Fuel injection
- Side impact beams
- Four wheeler dash board frame
- Shock absorber
- Silent blocks
- Control arms
- Gear shift lever

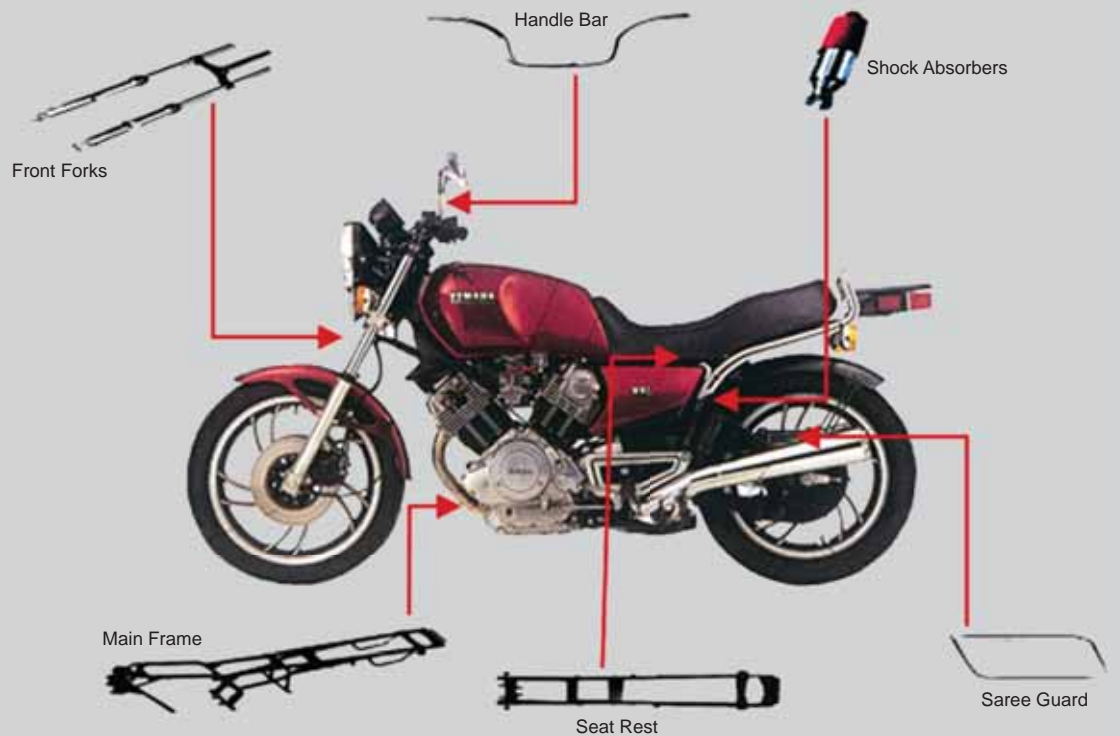

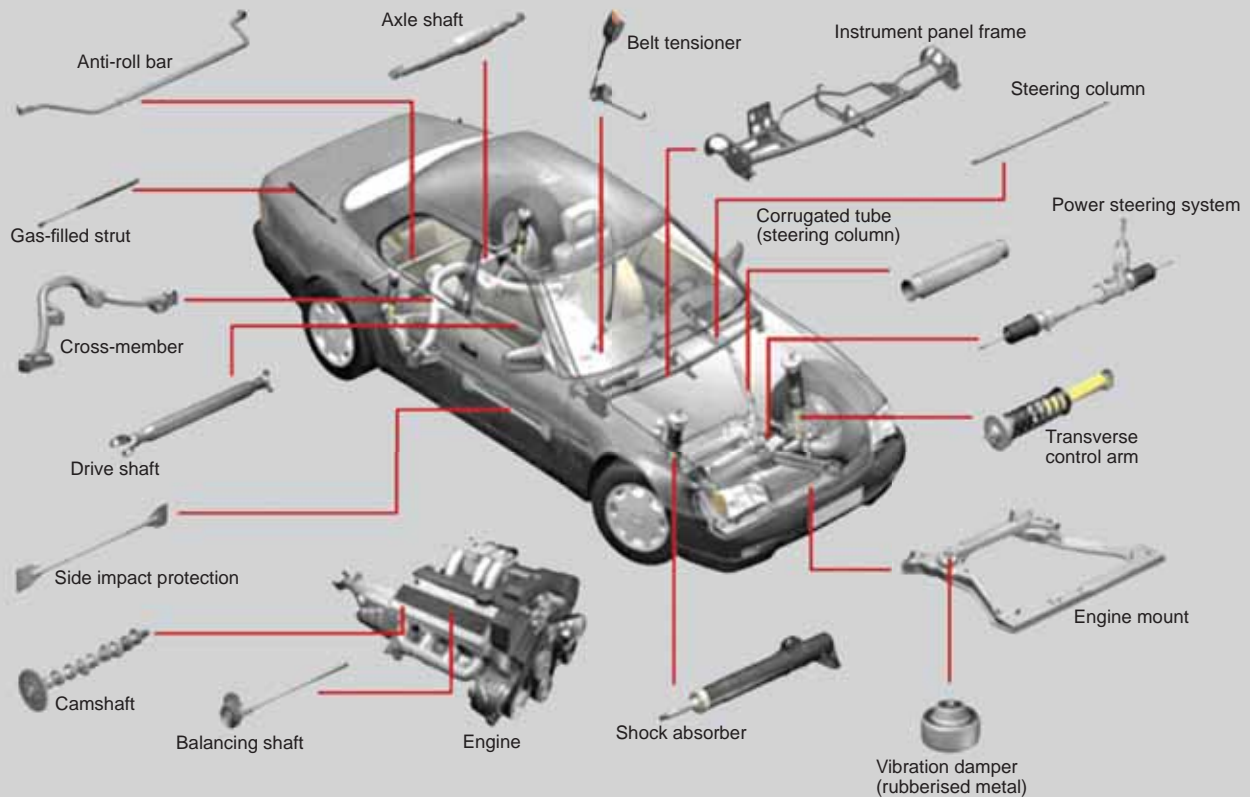

Boilers and Heaters

- Chemical / Sugar Industry
- Super heater
- Paper / Process Industry
- Air pre heater
- Heat exchanger

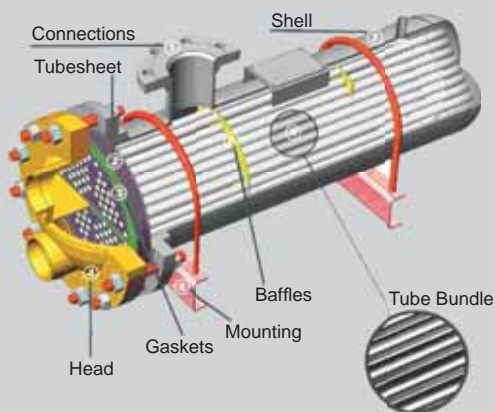

General Engineering

- Bearings and spindles, Trolley handles, Hydraulic and pneumatic line, Electrical conduit
- Oxygen lancing pipes, Cycle pumps, Industrial chain roller, Gas stove lighters
- Electrostatic precipitators
- Textile frames and Bobbins
- Main beam for pedestal fans
- GI pipes



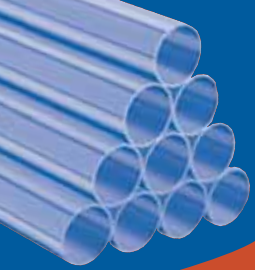

Electric Resistance Welded Tubes

Product Range

Size (mm)	Thickness (mm)													
	0.8	0.91	1.00	1.25	1.63	2.03	2.34	2.50	2.64	2.95	3.25	3.66	4.00	5.00
Square														
19														
25														
30														
31														
35														
38														
40														
45														
50														
50														
80														
100														
Rectangle														
30 X 20														
38 X 19														
40 X 10														
40 X 20														
40 X 30														
40 X 32														
50 X 20														
50 X 30														
50 X 25														
60 X 30														
60 X 40														
76 X 25														
80 X 40														
80 X 60														
80 X 80														
92 X 48														
100 X 50														
100 X 60														
100 X 80														
115 X 60														
115 X 69														
150 X 55														



Equivalent Standards for Products

Application	Indian	British	Japanese	German	American
Automobiles	IS 3074	BS 6323	JIS G 3445	DIN 2393	ASTM A 513
				DIN 2394	
Shock Absorbers	IS 3074	BS 6323	JIS G 3445	DIN 2393	ASTM A 513
Boilers	IS 1914	BS 3059	JIS G 3461		ASTM A 53
					ASTM A 214
Air Heaters	IS 3601	BS 3059	JIS G 3461	DIN 1717	ASTM A 214
Bicycles	IS 2039	BS 1717			
General Engg	IS 3601	BS 6323	JIS G 3445	DIN 2393 &94	
Transformers	IS 8036				
Furniture	IS 7138		JIS G 3445		
Sectional	IS 4923		JIS G 3466		ASTM A 500 Gr.A
Structural	IS 1161	BS 4360	JIS G 3444		ASTM A 500 Gr.A
Heat Exchanger		BS 3606	JIS G 3461	DIN 17177	ASTM A 178,214
Oil Pipes	IS 1978	BS 1387	JIS G 3452	DIN 17177	API 5L Gr.A
Idler Tubes	IS 9295				

Standards



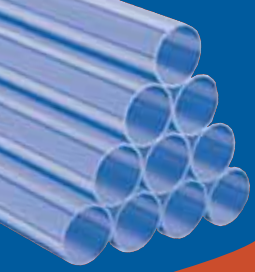

Quality Control

Quality Assurance

At Pennar, Quality Control is an integral part of the manufacturing process. It begins at the raw material stage where it is inspected for chemical composition and tested for other parameters like mechanical properties, gauge variation, etc.

In process Quality Control is carried out through both destructive and non-destructive tests for weld integrity. Destructive tests such as drift expansion test, flattening test and crushing test are done on-line and off-line. Non-destructive eddy current testing and pressure testing along with magnetic crack detector are carried out as specified by the customer.

All safety requirements are adhered to and critical parts undergo 100% non-destructive testing before packing and dispatch.

Mechanical testing for tensile strength is conducted as part of the process sequence in line with the customer's specifications. These include dimensional and visual checks for thickness, outside diameter, inside diameter, ovality, fin height, surface finish and other material defects. Inspection by third party and customer inspections are carried out, as required. Pennar plants have ISO 9001 international certification



Metallurgical Microscope 50X - 2000X



Tensile testing machine (40T capacity)



How to Order Steel Tubes?

Precision steel tubes can be manufactured to fit the exact requirements of the customer. This can be made possible, by filling in the following information.

Size

OD / ID	OD / Thick	Length

Category

ERW	CDW	Fin Cut	Non Fin Cut

Condition

Ordinary	Welded	Drawn	Clean Bore	Cylinder Bore

Specification

As Per Standards	Customer Requirement

End Application

(Please specify the sequence of operations carried out on the tube to help in building exact requirements while being manufactured at our end).

Finish Requirement

Painting	Zinc Plating	Chrome Plating

Monthly Requirement

(Tentative / Firm)

Length	Pieces (No's)

Delivery Schedule

Packing

(Please indicate if any special packing is required)

Additional Information

(Drawings or Samples if available)

Manufacturing facilities



Pennar Industries Limited

Registered Office

3rd Floor, DHFLVC, Silicon Towers, Kondapur, Hyderabad - 500084
Ph: +91-40-23117043 / 45 / 47 Fax: +91-40-23117041
www.pennarindia.com

Corporate Office

I.D.A, Patancheru - 502319, Medak District, Telangana, India.
Ph: 08455-242184 to 193 Fax: 08455-242424 / 242161
Email: pilhyd@bsnl.in / contact@pennarindia.com
www.pennarindia.com

Manufacturing Locations

Patancheru (Telangana)

Ph: 08455-242184 to 193 Fax: 08455-242424 / 242161
Email: pilhyd@bsnl.in / contact@pennarindia.com

Isnapur (Telangana)

Ph: 08455-226415 / 226617 Fax: 08455-226412

Chennai (Tamil Nadu)

Ph: 044-27629312 / 27629042 Fax: 044-2762 9298
Email: pilchn@pennarindia.com

Tarapur (Maharashtra)

Ph: 02525-272517 / 272609 Fax: 02525-272536
Email: pennar@sancharnet.in

Hosur (Tamil Nadu)

Ph: 04344-275458 Telefax: 04344-276874
Email: pilhsr@sancharnet.in



Patancheru (Telangana)



Isnapur (Telangana)



Chennai (Tamil Nadu)



Sadashivpet (Telangana)



Tarapur (Maharashtra)

Marketing Offices

Aurangabad	: +91 - 88888 77184
Ahmedabad	: +91 - 97254 04742
Bengaluru	: +91 - 99003 97731
Chennai	: +91 - 89398 67151
Coimbatore	: +91 - 98400 03021
Delhi	: +91 - 99112 50377
Hosur	: +91 - 90250 11108
Hyderabad	: +91 - 80965 57770
	: +91 - 95050 51459
Indore	: 0731-4207171
Kolkata	: +91 - 98304 90199
Mumbai	: +91 - 99309 01981
Pune	: +91 - 90280 97456

February 2015